

NTB-55-DOOR

Door open-in and out door systems (non-thermally broken)

The system is glazed internally to accommodate 24mm or 26mm double glazed units, using standard beads. As with all **Jalal** systems, the Door system is manufactured to exacting standards enabling economy to be combined with strength to give many years of aesthetic, trouble-free operation.

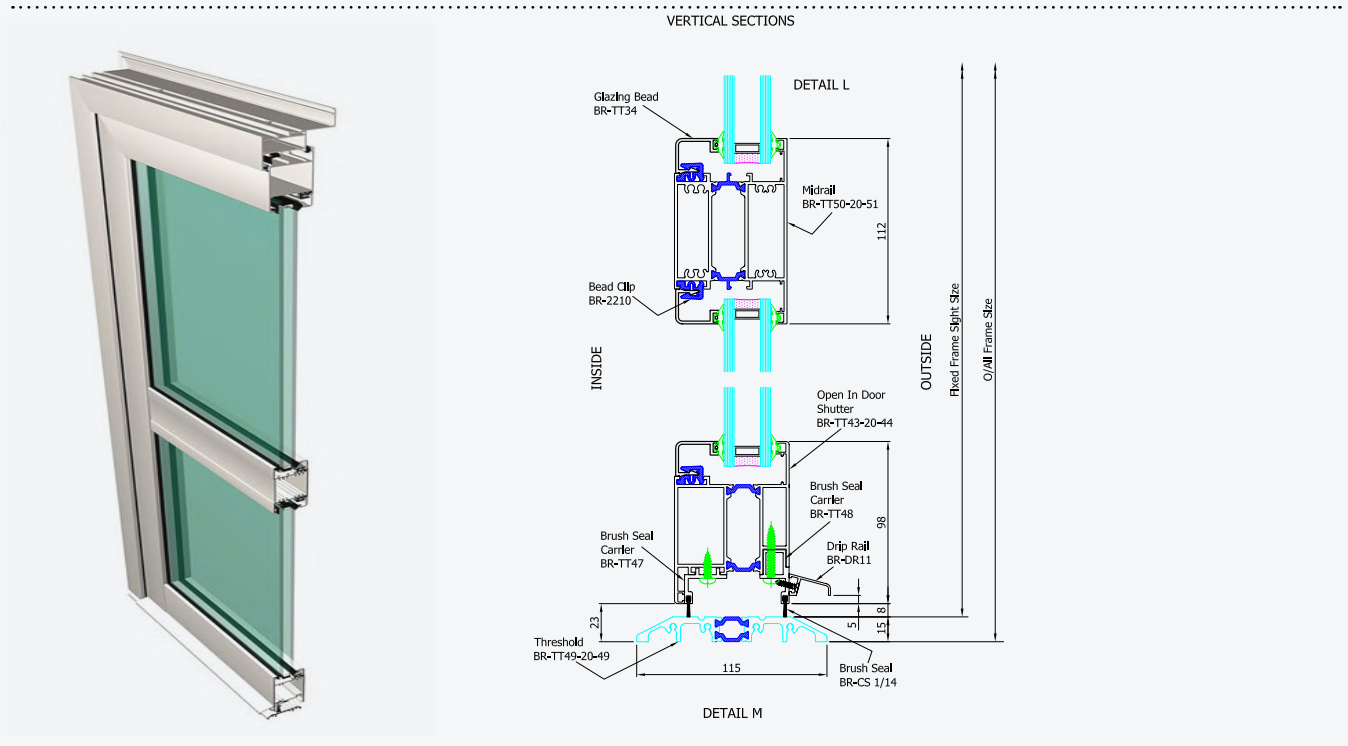

NTB-55-DOOR System Performance



SIZE

- Door shutter weights Medium Duty door with BR-8020 Hinge - 150kg (max)
- Bacony Door with two BR-9211.6 hinges - 80kg (max) with three BR-9211.6 hinges - 90kg (max) with two BR-8041.1 hinges - 90kg (max)



DESIGN

- Corners formed as 45 degree mitres to provide a quality appearance, high performance and weather resistance.
- All frame joints are fully sealed during manufacture.
- Opening panels fully weather-sealed with woolpile seals.



PERFORMANCE

- Economy is combined with strength to provide many years of trouble free operation and to be aesthetically pleasing.
- The **Jalal** thermally broken system should be used where additional thermal performance is required



INSTALLATION

- Detailed installation instructions are provided on our web site

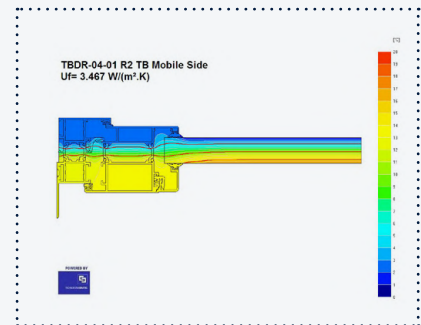

Isotherm Diagram



DISCOVER
MORE ON OUR
WEBSITE